

www.polymagnet.com

1000610

Align Polymagnets are designed to provide high holding force when aligned and low holding force when out of alignment. As these Polymagnets approach alignment they provide a positive force toward the alignment position. These Align Polymagnets have high shear resistance along their long axis.

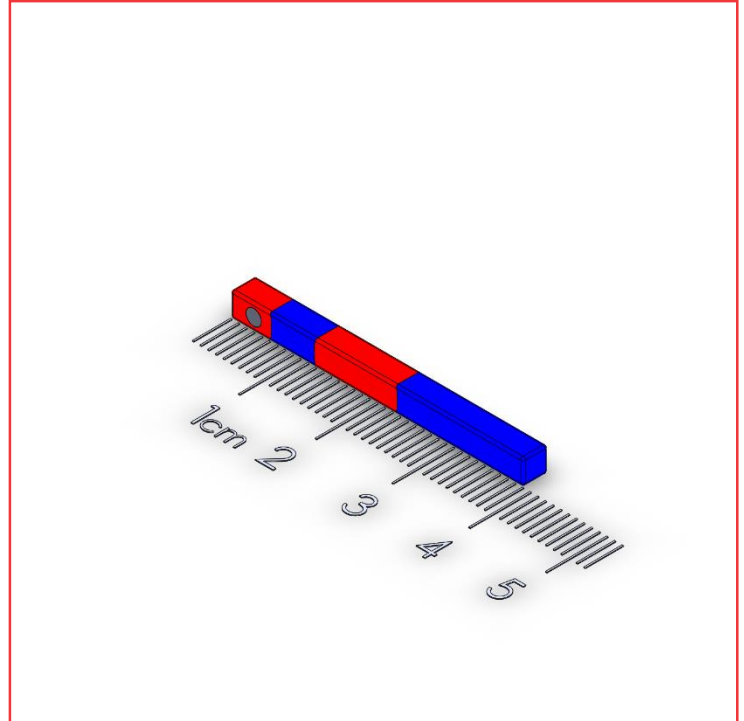

Features and Benefits

- Magnet-To-Magnet, Self-Aligning
- Alignment: 1D
- Shear Resistance: 1D
- Pairs With: SELF

Technical Specifications:

Dimensions:	1.5 x 0.125 x 0.125 in (38.1 x 3.175 x 3.175 mm)
Weight:	0.1 oz (2.9 g)
Material:	NdFeB
Magnet Grade:	N50
Coating:	Ni-Cu-Ni
Temperature Rating:	176 ° F (80 ° C)

www.polymagnet.com

Align Polymagnets provide superior linear alignment attributes compared to conventional magnets. A pair of 1000610 Polymagnets provide a strong force toward their alignment position when offset on their long axis. Because of their alignment and shear resistance attributes these magnets can be used to transfer a linear force across a gap.

*In the images below, north poles are indicated by red regions and south poles are indicated by blue regions. The images below refer to a pair of 1000610 Polymagnets.

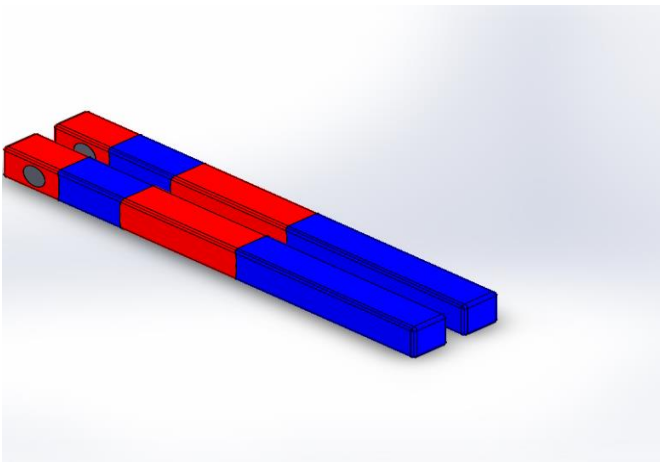

Aligned

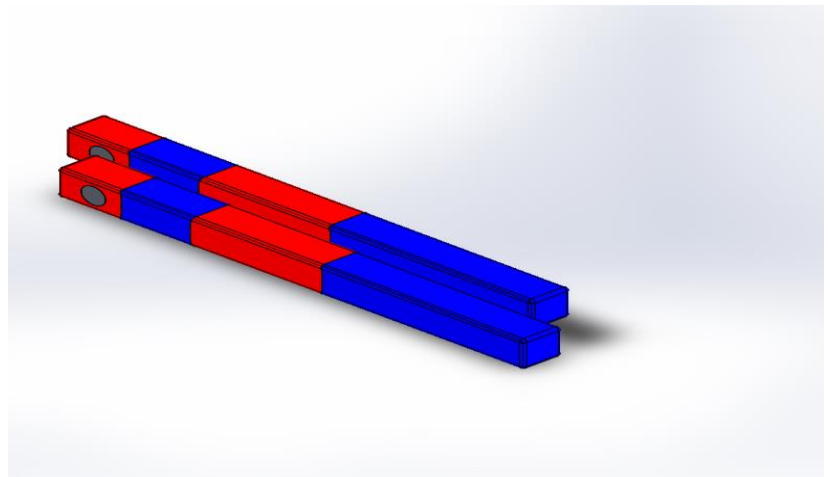

Horizontal Offset

HOLDING FORCE VS HORIZONTAL DISPLACEMENT AT 0.5MM MAGNET TO MAGNET GAP

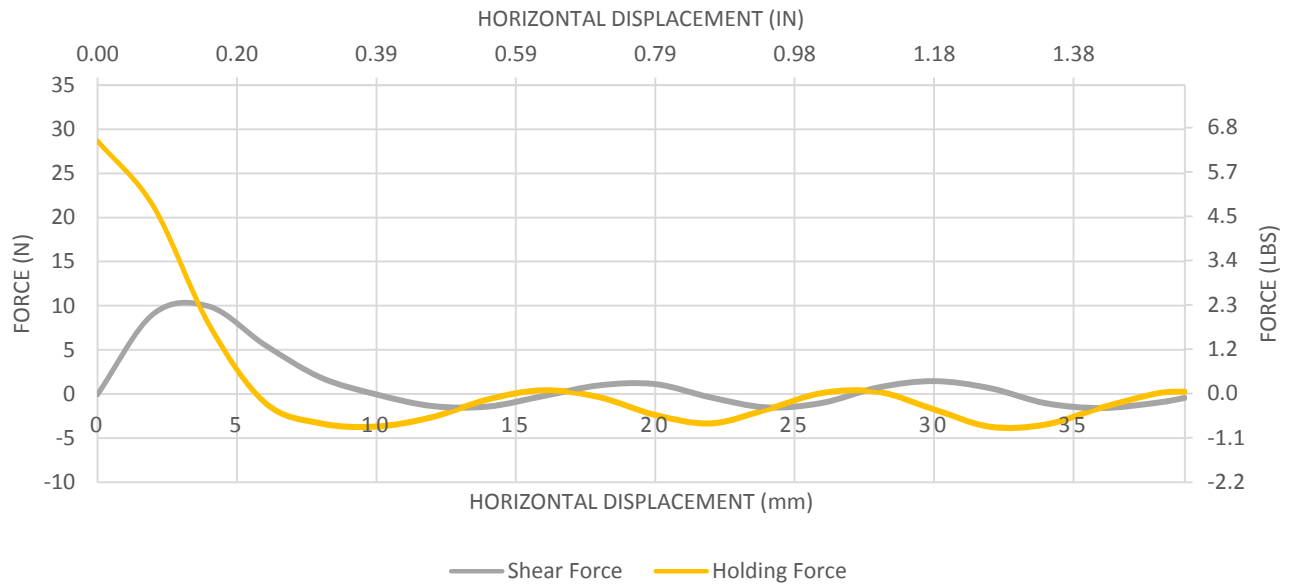

HOLDING FORCE VS HORIZONTAL DISPLACEMENT AT 1.0MM MAGNET TO MAGNET GAP

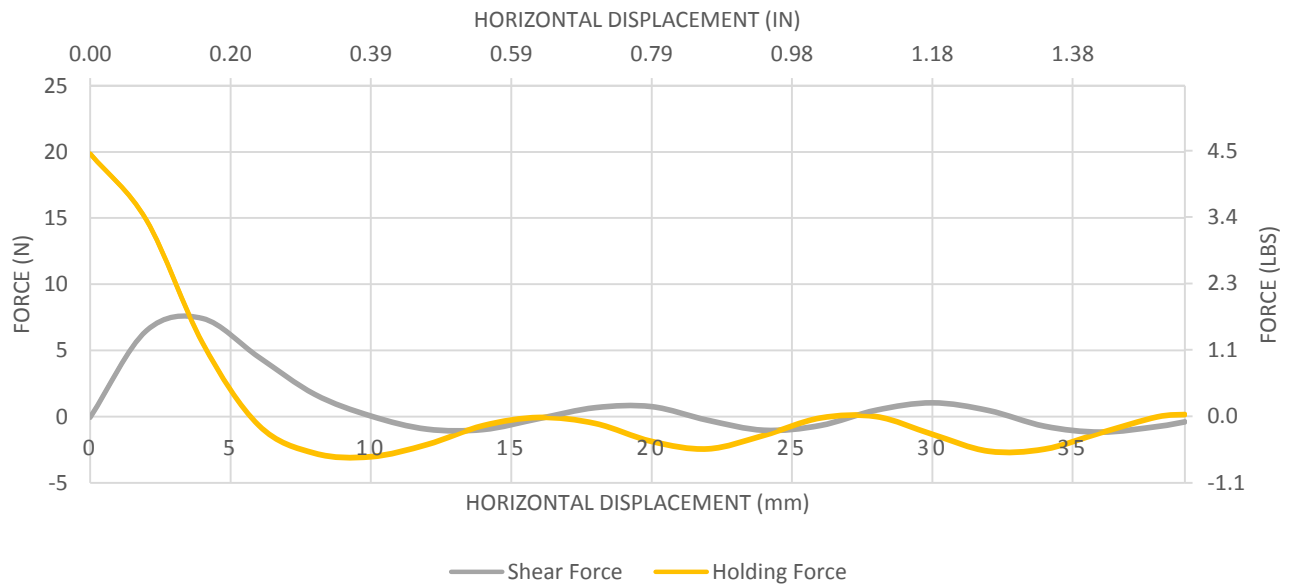

HOLDING FORCE VS HORIZONTAL DISPLACEMENT AT 1.5MM MAGNET TO MAGNET GAP

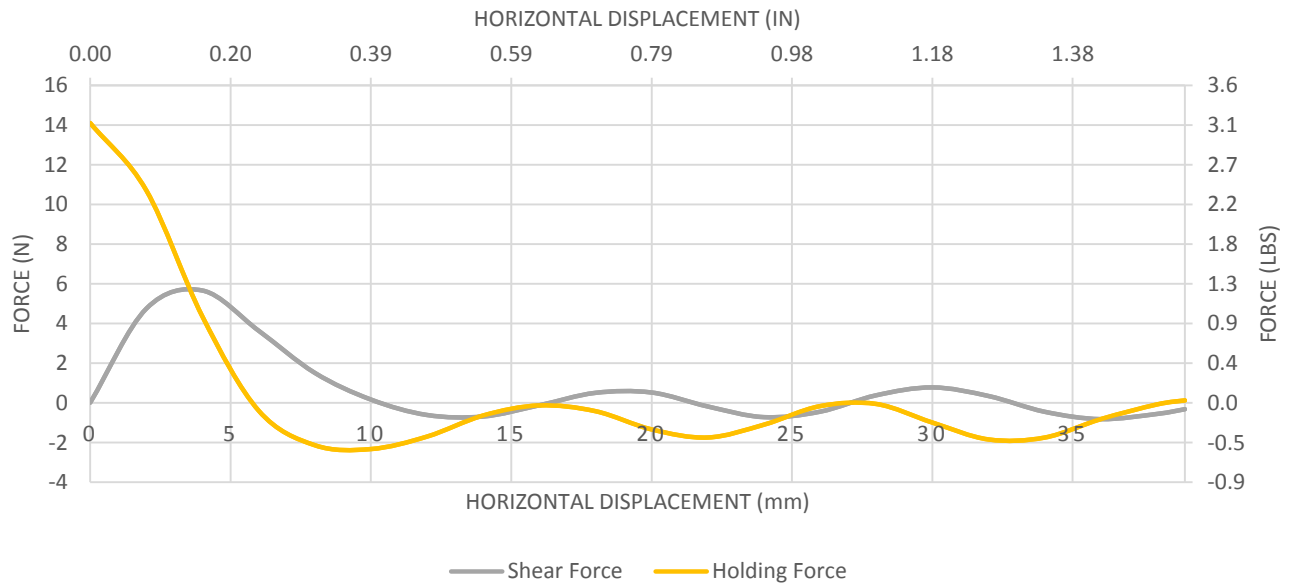

HOLDING FORCE VS HORIZONTAL DISPLACEMENT AT 2.0MM MAGNET TO MAGNET GAP

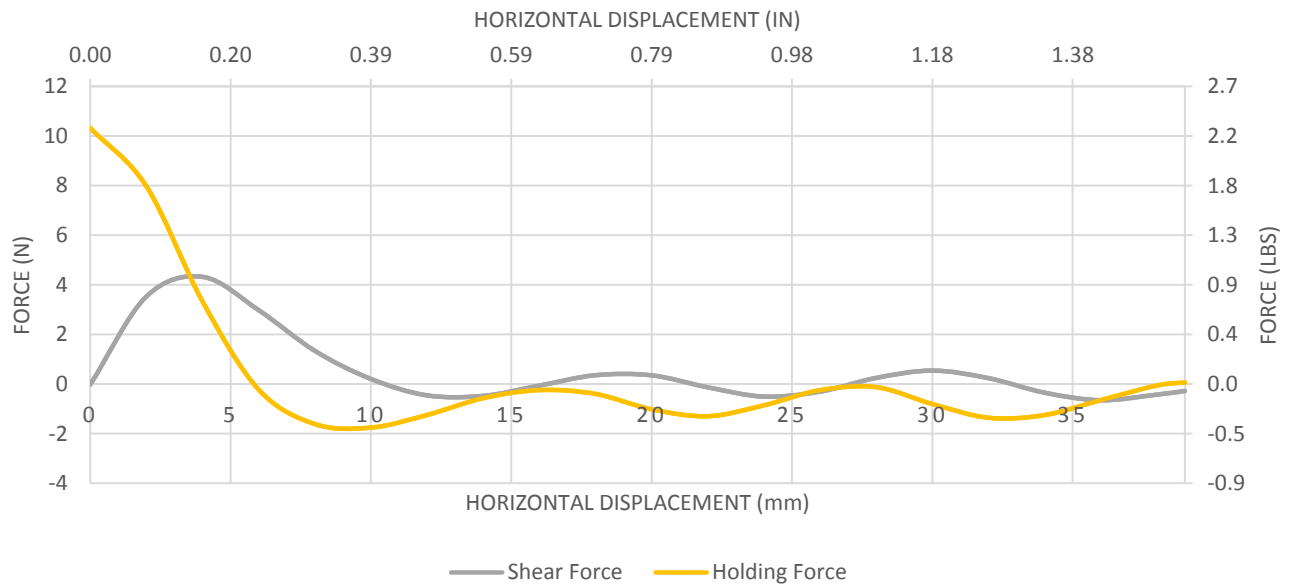

HOLDING FORCE VS SEPARATION DISTANCE MAGNET TO MAGNET

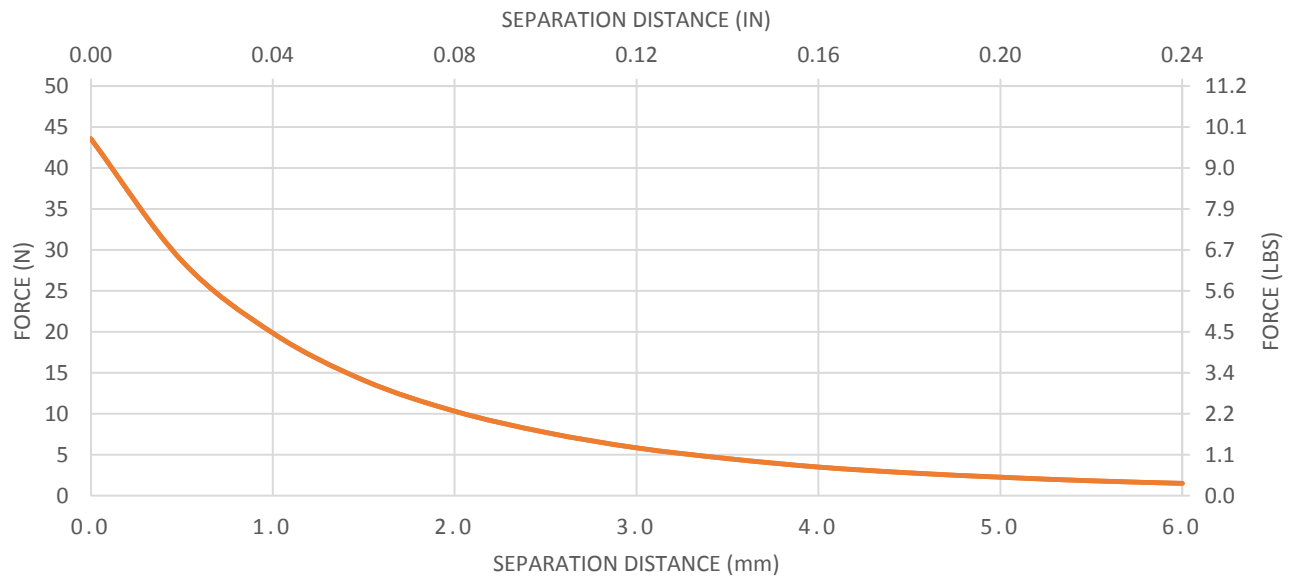

Target	Separation Distance						
	Contact	0.5mm (0.02in)	1.0mm (0.04in)	1.5mm (0.06in)	2.0mm (0.08in)	2.5mm (0.10in)	3.0mm (0.12in)
Magnet To Magnet SELF	43.6N (9.8LBF)	28.7N (6.4LBF)	19.9N (4.5LBF)	14.1N (3.2LBF)	10.3N (2.3LBF)	7.7N (1.7LBF)	5.8N (1.3LBF)

www.polymagnet.com

The holding strength for these Polymagnets can be enhanced in many applications by using a thin steel shunt directly against the back of the Polymagnet, and this shunt will also help limit stray fields from the shunt side of the magnet.

The image below shows the magnetic field differences between the Polymagnet without a shunt and the Polymagnet with a shunt.

Polymagnet with no shunt

Polymagnet with shunt

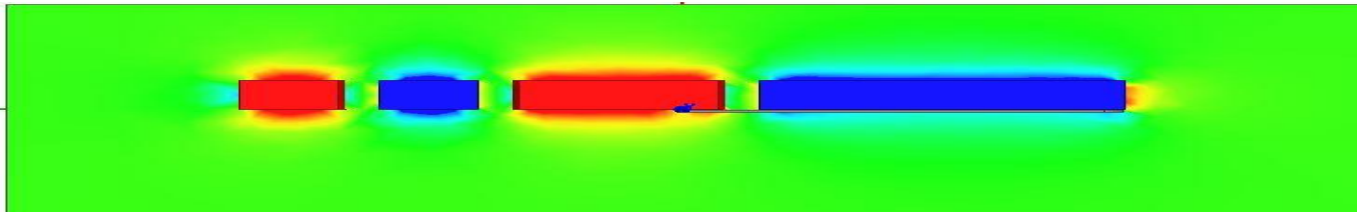

Notes on Performance Data

The performance information provided in this data sheet is derived from test or simulation results of directly comparable magnets of the same size and grade under consistent conditions. The magnets are tested under controlled environmental conditions. Unconstrained application testing may give lower forces due to the magnet tilting or shifting away from target during engagement and disengagement. Magnetic performance may vary by up to 7%, the values presented here are based on nominal magnetic properties

Patent Information

Pat. www.cmrpatents.com

